

#### 9071T 墙装式去水弯管

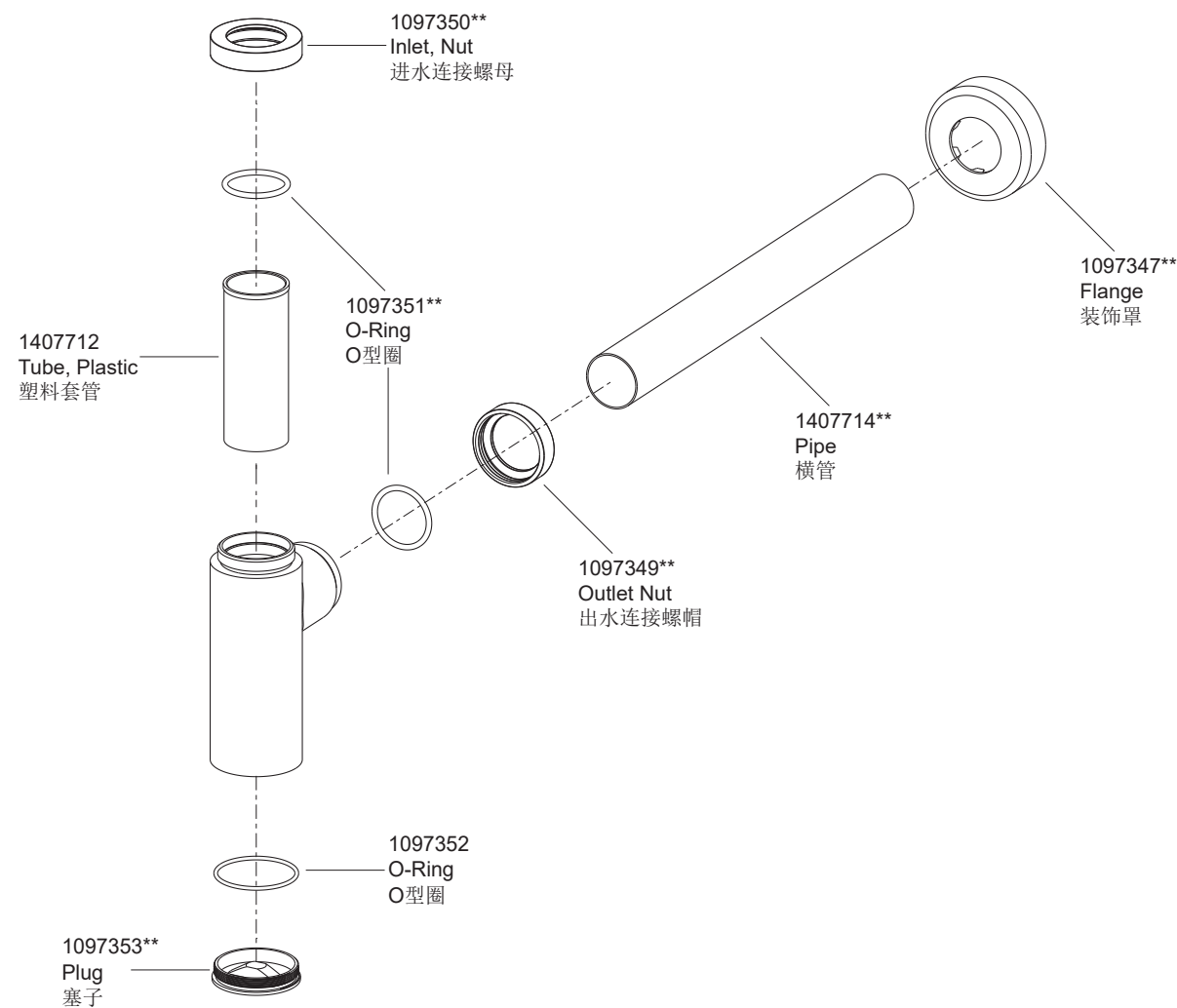

\*\*订购时请说明颜色编号

\*\*Color code must be specified when ordering

#### 9071T 墙装式去水弯管

#### 安装之前

所有的资料是按最新出版的产品资料编写而成。科勒公司保留任何时候不经通知即可改变产品特性、包装或产品可供类型的权利。

说明书包括重要的安装、保养及清洁方面的内容，请把这些资料交给用户阅读。

#### 注意事项：

1. 遵守当地管路安装条例。
2. 关闭主供水源。
3. 根据安装尺寸，预置墙内排水管。排水管内径略大于 $\text{Ø}32\text{mm}$ （推荐控制在 $33\sim 36\text{mm}$ 之间）。允许略高出装修好的墙面，但不大于 $10\text{mm}$ 。去水弯管的横管可伸入排水管长度不小于 $25\text{mm}$ 。

#### BEFORE YOU BEGIN

All information is based on the latest product information available at the time of publication. Kohler Co. reserves the right to make changes in product characteristics, packaging, or availability at any time without notice.

Please leave these instructions for the consumer. They contain important information.

#### NOTES:

1. Observe all local plumbing codes.
2. Shut off the main water supply.
3. According to rough-in dimensions, drain stub-out should be prearranged in the wall. Inside diameter of the drain stub-out must be little bigger  $\text{Ø}32\text{mm}$  (recommended  $33\sim 36\text{mm}$ ). It can extend beyond the wall, but no more than  $10\text{mm}$ . The pipe of the bottle trap can reach into drain stub-out no less than  $25\text{mm}$ .

#### 安装尺寸

#### ROUGH-IN DIMENSIONS

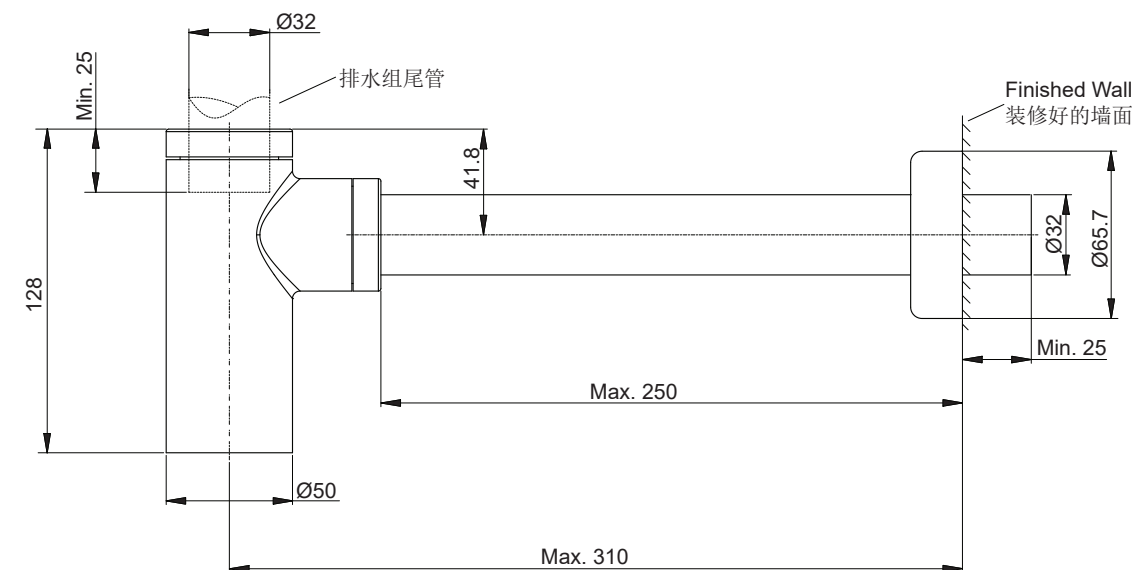

## 安装步骤

根据厂家的安装说明，安装排水组。

将去水弯管(6)上的进水连接螺帽(8)和O型圈(7)取下，依次将进水连接螺帽和O型圈套入排水组尾管(9)。将排水组尾管插入去水弯管进水口，保持去水弯管出水口正对排水口(1)，手动旋紧进水连接螺帽。

**注意：**确保尾管插入进水连接螺帽不少于25mm。

将去水弯管上的出水连接螺帽(4)和O型圈(5)取下。测量去水弯管的出水口同预置排水口间的距离，根据需要在同时确保横管(3)伸入去水弯管出水口和预置排水口(1)的长度不小于25mm的基础上，可适当切除横管，但避免损坏电镀表面。依次将出水连接螺帽和O型圈套入横管一端。将装饰罩(2)套入横管另一端。将横管同时插入去水弯管出水口和排水口。如横管不能同时插入去水弯管出水口和排水口，则需要调节去水弯管的高度。锁紧进出水连接螺帽(8、4)以固定去水弯管。用油灰或合适的密封胶填充横管同排水口内孔的间隙，去除多余油灰或密封胶。将装饰罩后推与墙面接触。

**注意：**确保横管插入出水口及排水口长度均不少于25mm。

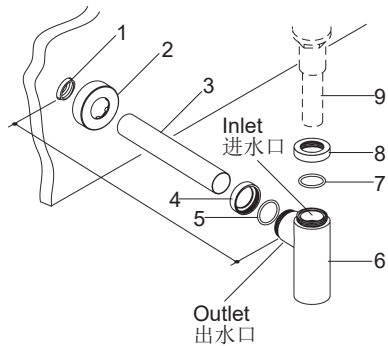

## INSTALLATION

Install the drain to lavatory according to the manufacturer installation instruction.

Remove the inlet nut(8) and O-ring(7) from the bottle trap body(6). With the threads facing down, slide the inlet nut with O-ring onto the tailpiece(9) of drain. Position the bottle trap body around the tailpiece and keep the outlet of bottle trap facing and aligning with drain stub-out(1). Then hand tighten the inlet nut.

**NOTE:** Ensure the tailpiece must be inserted at least 25mm inside the inlet nut.

Remove the outlet nut(4) and O-ring(5) from the bottle trap. The length of the pipe(3) should be about 25mm longer than the distance from drain stub-out(1) to the outlet. If more, cut it off as needed. Be careful, do not damage the finish. Slide the outlet nut and O-ring to one end of pipe, and flange(2) to the other end. Insert the pipe to the bottle trap outlet and drain stub-out. If can't do so, adjust the position of bottle trap. Tighten the inlet nut(8) and outlet nut(4) to secure the bottle trap. Fill up the gap between drain stub-out and pipe with plumber putty or sealants. Remove any excess putty or sealant. Push flange against the finished wall.

**NOTE:** Ensure the pipe must be inserted at least 25mm inside both the outlet of bottle trap and drain stub-out.

## 安装结果检查

检查并确保所有的衔接螺帽都已拧紧。

打开排水器和主要供水源，检查并修理有漏水的接口。

### 清理去水弯管杂质

用一字螺丝刀，逆时针转动并取下去水弯管塞子(11)，将塞子连同O型圈(10)放到一边。清理积在去水弯管(6)内的杂质，重新装回O型圈及塞子。

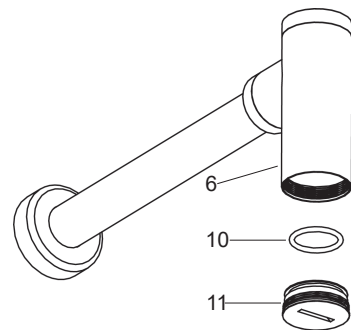

## INSTALLATION CHECKOUT

Ensure all coupling nuts are tightened.

Turn on the drain and main water supplies, check for leaks. Repair as needed.

### Clean Debris in Bottle Trap

Using a flat-blade screwdriver, turn the trap plug(11) counter-clockwise to remove it from the bottle trap body. Set the trap plug with O-ring(10) aside. Clean any debris that has collected in the bottle trap body(6). Reinstall the trap plug with the O-ring to the bottle trap body.

## 清洗说明

适用于所有加工处理过的表面：以中性肥皂水清洗镀层表面，再以干净的软布彻底擦干整个表面，许多清洁剂，比如氨水、去污粉及洁厕灵等，会对电镀表面造成伤害，切忌使用。

有磨损性的清洁用具或清洁剂也不可适用于科勒牌的水龙头及其配件上。

## CLEANING INSTRUCTIONS

All Finishes: Clean the finish with mild soap and warm water. Wipe entire surface completely dry with clean soft cloth. Many cleaners may contain chemicals, such as ammonia, chlorine, toilet cleaner etc. which could adversely affect the finish and are not recommended for cleaning.

Do not use abrasive cleaners or solvents on Kohler faucets and fittings.